

CD140M Dri-Prime® Pump

The Godwin Dri-Prime CD140M pump offers flow rates to 1240 USGPM and has the capability of handling solids up to 3.0" in diameter.

The CD140M is able to automatically prime to 28' of suction lift from dry. Automatic or manual starting/stopping available through integral mounted control panel or optional wireless-remote access.

Indefinite dry-running is no problem due to the unique Godwin liquid bath mechanical seal design. Solids handling, dry-running, and portability make the CD140M the perfect choice for dewatering and bypass applications.

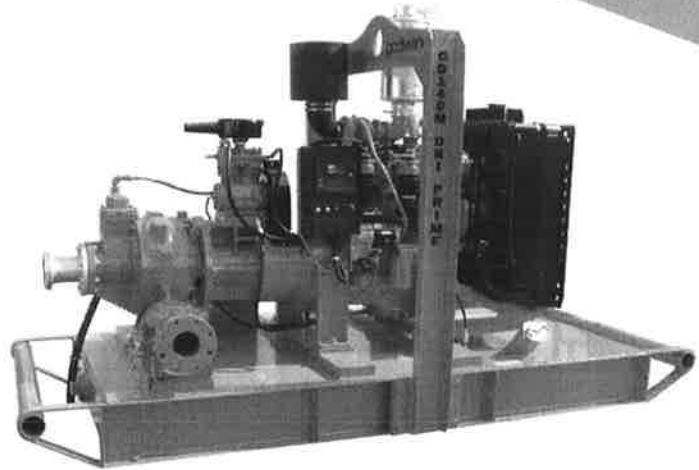

Features and Benefits

- Simple maintenance normally limited to checking fluid levels and filters.
- Dri-Prime (continuously operated Venturi air ejector priming device) requiring no periodic adjustment. Optional compressor clutch available.
- Extensive application flexibility handling sewage, slurries, and liquids with solids up to 3.0" in diameter.
- Dry-running high pressure liquid bath mechanical seal with high abrasion resistant solid silicon carbide faces.
- Close-coupled centrifugal pump with Dri-Prime system coupled to a diesel engine or electric motor.
- All cast iron construction (stainless steel construction option available) with cast steel impeller.
- Also available in a critically silenced unit which reduces noise levels to less than 70 dBA at 30'.
- Standard engine John Deere 4045TF285 (T3 Flex). Also available with John Deere 4045HFC92 (IT4).

Specifications

Suction connection	4" 150# ANSI B16.5
Delivery connection	4" 150# ANSI B16.5
Max capacity	1240 USGPM †
Max solids handling	3.0"
Max impeller diameter	13.6"
Max operating temp	176°F*
Max pressure	120 psi
Max suction pressure	58 psi
Max casing pressure	180 psi
Max operating speed	2000 rpm

* Please contact our office for applications in excess of 176°F.

† Larger diameter pipes may be required for maximum flows.

Performance Curve

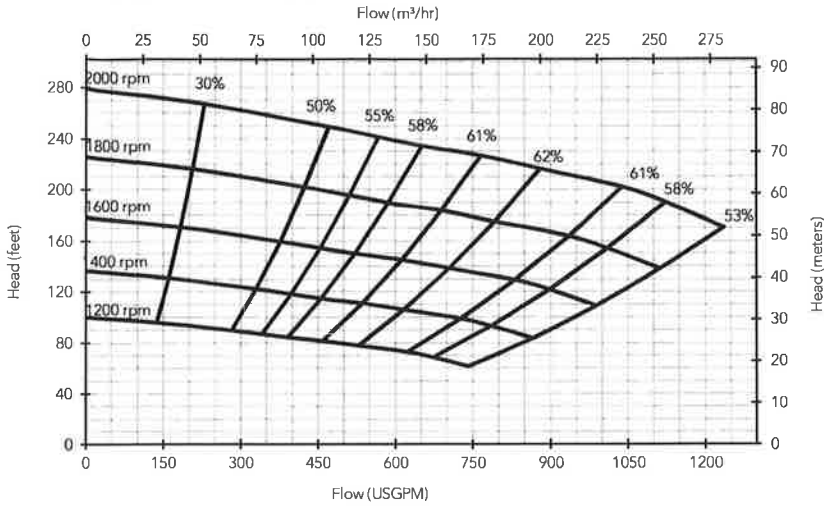

Engine option 1

John Deere 4045TF285 (T3 Flex), 93 HP @ 2000 rpm

Impeller diameter 13.6"

Pump speed 2000 rpm

Suction Lift Table

Total Suction Head (feet)	Total Delivery Head (feet)				
	144	164	185	205	237
10	1247	1213	1101	881	489
15	1247	1174	1027	807	391
20	978	905	832	704	294
25	758	753	709	612	196

Fuel capacity: 135 US Gal

Max Fuel consumption @ 2000 rpm: 5.4 US Gal/hr

Max Fuel consumption @ 1600 rpm: 4.4 US Gal/hr

Weight (Dry): 4,380 lbs

Weight (Wet): 5,350 lbs

Dim.: (L) 121" x (W) 53" x (H) 77"

Performance data provided in tables is based on water tests at sea level and 20°C ambient. All information is approximate and for general guidance only. Please contact the factory or office for further details.

Materials

Pump casing & suction cover	Cast iron BS EN 1561 - 1997
Wearplates	Cast iron BS EN 1561 - 1997
Pump Shaft	Carbon steel BS 970 - 1991 817M40T
Impeller	Cast Steel BS3100 A5 Hardness to 200 HB Brinell
Non-return valve body	Cast iron BS EN 1561 - 1997
Mechanical seal	Silicon carbide face; Viton elastomers; Stainless steel body

Engine option 2

John Deere 4045HFC92 (IT4), 97 HP @ 2000 rpm

Impeller diameter 13.6"

Pump speed 2000 rpm

Suction Lift Table

Total Suction Head (feet)	Total Delivery Head (feet)				
	144	164	185	205	237
10	1247	1213	1101	881	489
15	1247	1174	1027	807	391
20	978	905	832	704	294
25	758	753	709	612	196

Fuel capacity: 135 US Gal

Max Fuel consumption @ 2000 rpm: 5.1 US Gal/hr

Max Fuel consumption @ 1600 rpm: 4.5 US Gal/hr

Weight (Dry): 4,630 lbs

Weight (Wet): 5,600 lbs

Dim.: (L) 121" x (W) 53" x (H) 77"

Performance data provided in tables is based on water tests at sea level and 20°C ambient. All information is approximate and for general guidance only. Please contact the factory or office for further details.

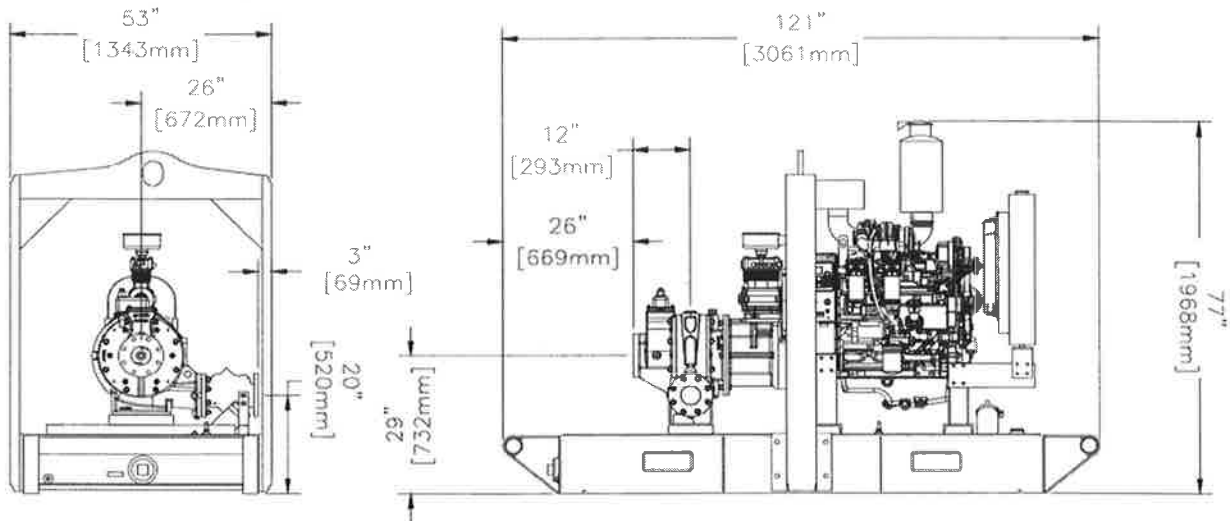

xylem
Let's Solve Water

84 Floodgate Road
Bridgeport, NJ 08014 USA
(856) 467-3636, Fax (856) 467-4841
Email: sales@godwinpumps.com

Reference number : 95-1009-3000
Date of issue : February 26, 2014
Issue : 5

www.godwinpumps.com

September 4, 2015

Mr. Alan Neff
Town of Yorktown
PO Box 518
Yorktown, IN 47396-0518

Phone: (765) 759-4002
Email: aneff@yorktownindiana.org

**RE: CD104M Sale
Sale Quotation 137002939**

Dear Mr. Neff:

Thank you for your interest in Xylem Dewatering Solutions. Per your request, we are pleased to provide the following sale quotation for a new four (4) inch high head diesel pumping equipment model CD140M.

The Godwin Dri-Prime® Model CD140M is a four (4) inch diesel, auto-priming pumpset. This pumpset has maximum flow capabilities of 1,240 Gallons per Minute (GPM), 260 feet of Total Dynamic Head (TDH) maximum and solids handling up to three (3) inches in diameter. This pumpset can handle a wide variety of applications.

This pumpset has the following features;

- Pump can handle raw sewage, sludge and liquids
- Automatic priming from dry up to 28 feet
- Cast steel impeller
- Trailer Mounted
- Interim tier 4 compliant
- Liquid bath mechanical seal for dry running indefinitely
- Double walled fuel tanks for environmental protection
- Prime Guard Controller

As you may know, the Godwin Dri-Prime® is a totally automatic self-priming centrifugal pump, which can achieve suction lifts from a completely dry condition to 28 feet. The priming system utilizes a compressor, driven directly off the engine, which moves air across a set of venturis. This action creates a vacuum, drawing the water into the pump. The pump is primed automatically, quickly and repeatedly as needed.

Home Office:

We are including a specification sheet, along with a pump curve, on each model, for your reference.

As a standard option we have included our PrimeGuard Controller which will activate the automatic start / stop float system along with a number of other electronic functions. The PrimeGuard can also assist you with scheduled maintenance, pump diagnostics, and the ability to have remote monitoring of the pumping system when it is equipped with Field Smart Technology (FST).

Also, we have included heavy duty suction hose, suction screen, and layflat discharge hose. The hose is listed with Godwin Quick Disconnect (QD) fittings and Cam & Groove fittings, for your reference.

Once you have had time to review the attached documents and system curves, we would like to schedule a time to bring a demo pump to your facility and discuss the features in greater detail.

The pumpset can be delivered within four (4) to six (6) weeks, upon receipt of your purchase order.

We are quoting this pumpset at General Services Administration (GSA) pricing.

Please keep in mind that Xylem Dewatering Solutions is responsive around the clock to make sure your complete satisfaction is guaranteed before, during and after your purchase. If you have any questions or require additional information, please feel free to contact me directly at 317-945-4161 or the office at 317-217-5131. We look forward to assisting you with this purchase.

Sincerely,

A handwritten signature in black ink, appearing to read "John Murray", with a long, sweeping horizontal stroke extending to the right.

John Murray
Outside Sales Representative

JM / mr

SUPPLEMENTAL CONTRACT TERMS AND CONDITIONS

Lessor/Supplier and Customer agree that the terms and conditions printed below are material elements of this contract (the "Contract"),

OWNERSHIP: FOR RENTED GOODS, RIGHTS AND TITLE SHALL REMAIN WITH THE LESSOR AT ALL TIMES. FOR SALE GOODS, RIGHTS AND TITLE SHALL PASS TO CUSTOMER ON THE EARLIER OF SUPPLIER'S RECEIPT OF PAYMENT IN FULL OR CUSTOMER'S RECEIPT OF GOODS AT THE FOB POINT SPECIFIED IN THIS CONTRACT.

ACCEPTANCE/MODIFICATION: Customer's notice to proceed or possession of the goods shall be deemed agreement to and acceptance of the Contract. Any purchase order or other document submitted by Customer with differing terms or conditions applicable to the goods is hereby rejected. This Contract contains the entire agreement between the Lessor/Supplier and the Customer. No modification of this Contract shall be binding upon Lessor/Supplier unless such modifications are in writing and signed by both parties.

SHIPMENT: Customer shall obtain goods at Lessor's/Supplier's facility unless Lessor/Supplier agrees to ship goods or to make delivery. If goods are to be shipped or delivered by Lessor/Supplier, prices are exclusive of the costs thereof, and unless different terms are stated by Lessor/Supplier in this Contract, all prices are F.O.B. Supplier's facility.

REMOVAL: Customer agrees not to remove rented goods from the original delivery location without the prior written consent of the Lessor, which shall not be unreasonably withheld.

RENTAL CHARGES: Customer will be charged rental from delivery date up to and including date Customer obtains an Off Rent Call Confirmation Number from Lessor. All rental charges are based on an eight hour working day, 48 hour working week, or 28 day month, and no reduction in rental charges will be made for any time the goods are not used while in Customer's possession and control. Customer agrees to report and pay for any overtime use of the goods in any day, or week or month, at the proportional rental charge specified in this Contract. If no time is fixed for rental period, or if rental is extended beyond the fixed period of time, the Customer agrees to give the Supplier four (4) full business days notice of termination of rental in writing. The rented goods are furnished F.O.B. Lessor's facility and all handling and transportation charges to and from Lessor's facility, unless otherwise specified herein, shall be paid by Customer.

CREDIT/PAYMENT TERMS: Credit terms are subject to the approval of Supplier's credit department. If credit terms are not approved, sale will be C.O.D. Rentals shall be payable in advance for each rental period, and, after the expiration of the minimum guaranteed rental period, rents shall be payable per the Contract until the rented goods are returned by Customer. Standard terms of payment are net 30 days from date of invoice. A late fee of 1½ percent per month shall be charged on all balances over 30 days. Customer agrees to pay all costs, including reasonable attorneys' fees, incurred as a result of Customer's breach of this Contract including the failure to pay any amounts due hereunder.

INSURANCE: Customer must maintain specific insurance coverages when renting goods from Supplier: Statutory Workers' Compensation and Employers' Liability in compliance with state laws; Automobile Liability including owned, hired, and non-owned vehicles; and Commercial General Liability on a primary and non-contributory basis including broad form contractual liability coverage. Minimum per occurrence limits of \$1MM must be per location/job and defense cost must be supplementary payments. Claims-made policies are not acceptable. Rented/leased equipment must be covered by a Contractor's Equipment policy for the full replacement value of the equipment. Customer must provide a Certificate of Insurance with endorsements naming Supplier as the Certificate Holder and must state that Lessor is named as additional insured and loss payee. Expiration dates, limits, and deductibles for each policy must also be noted, along with a provision for notice of cancellation, non renewal, or material change to the certificate holder of not less than 30 days. Customer shall provide a Certificate of Insurance with endorsements as evidence of coverage before Supplier will release the goods. Failure to maintain adequate insurance will result in an additional automatic surcharge of 15% to the total equipment charge and Customer shall remain subject to the Loss/Damages provisions herein whether insured or not.

LOSS/DAMAGES: Customer shall be responsible for all loss or damage to rented goods occurring in excess of ordinary wear and tear, or by theft or fault, negligence or shortages up to the full replacement value of the goods, Lessor's pick-up receipt for rental goods shall not be construed as Lessor's final clearance to Customer. Customer may be invoiced separately for loss or damages to goods.

OPERATION/INSPECTION: Customer agrees to operate the equipment in accordance with the manufacturer's manuals and instructions. Customer further agrees to place a competent operator in charge of the equipment. The operator shall be responsible for conducting a personal inspection of the equipment to reveal any apparent defects in the equipment and shall immediately notify Lessor of such defects to allow for repair or replacement of the equipment at Lessor's sole discretion. Customer shall operate the equipment at Customer's own risk.

SERVICE/MAINTENANCE: Customer shall be responsible for all fuel and add oils necessary to operate the equipment, and to check same daily to ensure proper operation of the equipment. Normal equipment maintenance is completed after 250 hours of running time, which can be provided by Lessor/Supplier for an additional charge. For rentals, Lessor shall have the right to enter the premises where the rental equipment is located and be given free access thereto and afforded necessary services and facilities for safely and readily inspecting it. Lessor reserves the right to conduct equipment maintenance if Customer has not completed maintenance by a qualified individual. Customer expressly agrees to maintain rental equipment and return it in the same condition as when received, normal wear and tear accepted, or to pay for any repairs that may be necessary, including cleaning.

WARRANTY: EXCEPT FOR WRITTEN WARRANTIES ON GOODS SOLD, LESSOR/SUPPLIER MAKES NO WARRANTIES, EITHER EXPRESS OR IMPLIED, INCLUDING AS TO MERCHANTABILITY OR FITNESS FOR ANY PARTICULAR PURPOSE.

INDEMNIFICATION: TO THE FULLEST EXTENT PERMITTED BY LAW, CUSTOMER AGREES TO DEFEND, INDEMNIFY AND HOLD HARMLESS LESSOR/SUPPLIER FROM AND AGAINST ANY AND ALL POTENTIAL CLAIMS, LIABILITIES, DEMANDS, SUITS, JUDGMENTS, AND THE ASSOCIATED COSTS AND EXPENSE (INCLUDING REASONABLE ATTORNEYS' FEES), WHICH LESSOR/SUPPLIER MAY INCUR, BECOME RESPONSIBLE FOR OR PAY OUT AS A RESULT OF DEATH OR PERSONAL INJURY TO ANY PERSON OR DESTRUCTION OR DAMAGE TO ANY PROPERTY, CAUSED IN WHOLE OR IN PART, BY THE OPERATION, MAINTENANCE, HANDLING OR TRANSPORTATION OF THE EQUIPMENT, LOSS OF USE, BUSINESS INTERRUPTION OR EXTRA EXPENSE DUE TO EQUIPMENT BREAKDOWN WHILE IN THE CUSTOMER'S CARE, CUSTODY OR CONTROL, OR WHILE IT IS BEING USED FOR CUSTOMER'S WORK. THESE PROVISIONS SHALL SURVIVE TERMINATION OR EXPIRATION OF THE CONTRACT.

LIMITATION OF LIABILITY: LESSOR/SUPPLIER LIABILITY, IF ANY, SHALL BE LIMITED TO THE VALUE OF THIS CONTRACT OR \$100, WHICHEVER IS GREATER. UNDER NO CIRCUMSTANCES SHALL LESSOR/SUPPLIER BE LIABLE TO CUSTOMER OR ANY THIRD-PARTY FOR ANY INDIRECT, SPECIAL, INCIDENTAL OR CONSEQUENTIAL DAMAGES WHETHER BASED ON CONTRACT, TORT (INCLUDING NEGLIGENCE), STRICT LIABILITY OR OTHERWISE.

DEFAULT/DAMAGES: If Customer is in breach of or default in any terms and conditions of this Contract, Lessor/Supplier may terminate this Contract and without demand or notice take immediate possession of, and remove any or all of, the equipment and return it to Lessor's/Supplier's facility, without liability for damages in trespass or otherwise, and without thereby waiving any claim Lessor/Supplier may have against Customer. Customer shall be responsible for all direct and indirect costs along with general and consequential damages, including reasonable attorney's fees and court costs, from Customer's breach of or default in any of the terms and conditions of this Contract.

JURISDICTION/VENUE: This Contract shall be governed by the laws of the State of New Jersey, without regard to its principles of conflicts of laws. Any action against Lessor/Supplier shall be filed in the Federal or State Courts of the State of New Jersey. Lessor/Supplier, at its option, may prosecute collections where debts accrue.

WAIVER: Lessor's/Supplier's waiver of any right under this agreement shall not affect future application of any such provision or any other provision.

SEVERABILITY: The provisions of this contract shall be severable so that the invalidity, unenforceability or waiver of any provision shall not affect the remaining provisions.

SUPPLEMENTAL CONTRACT TERMS AND CONDITIONS

Lessor/Supplier and Customer agree that the terms and conditions printed below are material elements of this contract (the "Contract").

OWNERSHIP: FOR RENTED GOODS, RIGHTS AND TITLE SHALL REMAIN WITH THE LESSOR AT ALL TIMES. FOR SALE GOODS, RIGHTS AND TITLE SHALL PASS TO CUSTOMER ON THE EARLIER OF SUPPLIER'S RECEIPT OF PAYMENT IN FULL OR CUSTOMER'S RECEIPT OF GOODS AT THE FOB POINT SPECIFIED IN THIS CONTRACT.

ACCEPTANCE/MODIFICATION: Customer's notice to proceed or possession of the goods shall be deemed agreement to and acceptance of the Contract. Any purchase order or other document submitted by Customer with differing terms or conditions applicable to the goods is hereby rejected. This Contract contains the entire agreement between the Lessor/Supplier and the Customer. No modification of this Contract shall be binding upon Lessor/Supplier unless such modifications are in writing and signed by both parties.

SHIPMENT: Customer shall obtain goods at Lessor's/Supplier's facility unless Lessor/Supplier agrees to ship goods or to make delivery. If goods are to be shipped or delivered by Lessor/Supplier, prices are exclusive of the costs thereof, and unless different terms are stated by Lessor/Supplier in this Contract, all prices are F.O.B. Supplier's facility.

REMOVAL: Customer agrees not to remove rented goods from the original delivery location without the prior written consent of the Lessor, which shall not be unreasonably withheld.

RENTAL CHARGES: Customer will be charged rental from delivery date up to and including date Customer obtains an Off Rent Call Confirmation Number from Lessor. All rental charges are based on an eight hour working day, 48 hour working week, or 28 day month, and no reduction in rental charges will be made for any time the goods are not used while in Customer's possession and control. Customer agrees to report and pay for any overtime use of the goods in any day, or week or month, at the proportional rental charge specified in this Contract. If no time is fixed for rental period, or if rental is extended beyond the fixed period of time, the Customer agrees to give the Supplier four (4) full business days notice of termination of rental in writing. The rented goods are furnished F.O.B. Lessor's facility and all handling and transportation charges to and from Lessor's facility, unless otherwise specified herein, shall be paid by Customer.

CREDIT/PAYMENT TERMS: Credit terms are subject to the approval of Supplier's credit department. If credit terms are not approved, sale will be C.O.D. Rentals shall be payable in advance for each rental period, and, after the expiration of the minimum guaranteed rental period, rents shall be payable per the Contract until the rented goods are returned by Customer. Standard terms of payment are net 30 days from date of invoice. A late fee of 1½ percent per month shall be charged on all balances over 30 days. Customer agrees to pay all costs, including reasonable attorneys' fees, incurred as a result of Customer's breach of this Contract including the failure to pay any amounts due hereunder.

INSURANCE: Customer must maintain specific insurance coverages when renting goods from Supplier: Statutory Workers' Compensation and Employers' Liability in compliance with state laws; Automobile Liability including owned, hired, and non-owned vehicles; and Commercial General Liability on a primary and non-contributory basis including broad form contractual liability coverage. Minimum per occurrence limits of \$1MM must be per location/job and defense cost must be supplementary payments. Claims-made policies are not acceptable. Rented/leased equipment must be covered by a Contractor's Equipment policy for the full replacement value of the equipment. Customer must provide a Certificate of Insurance with endorsements naming Supplier as the Certificate Holder and must state that Lessor is named as additional insured and loss payee. Expiration dates, limits, and deductibles for each policy must also be noted, along with a provision for notice of cancellation, non renewal, or material change to the certificate holder of not less than 30 days. Customer shall provide a Certificate of Insurance with endorsements as evidence of coverage before Supplier will release the goods. Failure to maintain adequate insurance will result in an additional automatic surcharge of 15% to the total equipment charge and Customer shall remain subject to the Loss/Damages provisions herein whether insured or not.

LOSS/DAMAGES: Customer shall be responsible for all loss or damage to rented goods occurring in excess of ordinary wear and tear, or by theft or fault, negligence or shortages up to the full replacement value of the goods. Lessor's pick-up receipt for rental goods shall not be construed as Lessor's final clearance to Customer. Customer may be invoiced separately for loss or damages to goods.

OPERATION/INSPECTION: Customer agrees to operate the equipment in accordance with the manufacturer's manuals and instructions. Customer further agrees to place a competent operator in charge of the equipment. The operator shall be responsible for conducting a personal inspection of the equipment to reveal any apparent defects in the equipment and shall immediately notify Lessor of such defects to allow for repair or replacement of the equipment at Lessor's sole discretion. Customer shall operate the equipment at Customer's own risk.

SERVICE/MAINTENANCE: Customer shall be responsible for all fuel and add oils necessary to operate the equipment, and to check same daily to ensure proper operation of the equipment. Normal equipment maintenance is completed after 250 hours of running time, which can be provided by Lessor/Supplier for an additional charge. For rentals, Lessor shall have the right to enter the premises where the rental equipment is located and be given free access thereto and afforded necessary services and facilities for safely and readily inspecting it. Lessor reserves the right to conduct equipment maintenance if Customer has not completed maintenance by a qualified individual. Customer expressly agrees to maintain rental equipment and return it in the same condition as when received, normal wear and tear accepted, or to pay for any repairs that may be necessary, including cleaning.

WARRANTY: EXCEPT FOR WRITTEN WARRANTIES ON GOODS SOLD, LESSOR/SUPPLIER MAKES NO WARRANTIES, EITHER EXPRESS OR IMPLIED, INCLUDING AS TO MERCHANTABILITY OR FITNESS FOR ANY PARTICULAR PURPOSE.

INDEMNIFICATION: TO THE FULLEST EXTENT PERMITTED BY LAW, CUSTOMER AGREES TO DEFEND, INDEMNIFY AND HOLD HARMLESS LESSOR/SUPPLIER FROM AND AGAINST ANY AND ALL POTENTIAL CLAIMS, LIABILITIES, DEMANDS, SUITS, JUDGMENTS, AND THE ASSOCIATED COSTS AND EXPENSE (INCLUDING REASONABLE ATTORNEYS' FEES), WHICH LESSOR/SUPPLIER MAY INCUR, BECOME RESPONSIBLE FOR OR PAY OUT AS A RESULT OF DEATH OR PERSONAL INJURY TO ANY PERSON OR DESTRUCTION OR DAMAGE TO ANY PROPERTY, CAUSED IN WHOLE OR IN PART, BY THE OPERATION, MAINTENANCE, HANDLING OR TRANSPORTATION OF THE EQUIPMENT, LOSS OF USE, BUSINESS INTERRUPTION OR EXTRA EXPENSE DUE TO EQUIPMENT BREAKDOWN WHILE IN THE CUSTOMER'S CARE, CUSTODY OR CONTROL, OR WHILE IT IS BEING USED FOR CUSTOMER'S WORK. THESE PROVISIONS SHALL SURVIVE TERMINATION OR EXPIRATION OF THE CONTRACT.

LIMITATION OF LIABILITY: LESSOR/SUPPLIER LIABILITY, IF ANY, SHALL BE LIMITED TO THE VALUE OF THIS CONTRACT OR \$100, WHICHEVER IS GREATER. UNDER NO CIRCUMSTANCES SHALL LESSOR/SUPPLIER BE LIABLE TO CUSTOMER OR ANY THIRD-PARTY FOR ANY INDIRECT, SPECIAL, INCIDENTAL OR CONSEQUENTIAL DAMAGES WHETHER BASED ON CONTRACT, TORT (INCLUDING NEGLIGENCE), STRICT LIABILITY OR OTHERWISE.

DEFAULT/DAMAGES: If Customer is in breach of or default in any terms and conditions of this Contract, Lessor/Supplier may terminate this Contract and without demand or notice take immediate possession of, and remove any or all of, the equipment and return it to Lessor's/Supplier's facility, without liability for damages in trespass or otherwise, and without thereby waiving any claim Lessor/Supplier may have against Customer. Customer shall be responsible for all direct and indirect costs along with general and consequential damages, including reasonable attorney's fees and court costs, from Customer's breach of or default in any of the terms and conditions of this Contract.

JURISDICTION/VENUE: This Contract shall be governed by the laws of the State of New Jersey, without regard to its principles of conflicts of laws. Any action against Lessor/Supplier shall be filed in the Federal or State Courts of the State of New Jersey. Lessor/Supplier, at its option, may prosecute collections where debts accrue.

WAIVER: Lessor's/Supplier's waiver of any right under this agreement shall not affect future application of any such provision or any other provision.

SEVERABILITY: The provisions of this contract shall be severable so that the invalidity, unenforceability or waiver of any provision shall not affect the remaining provisions.

SALE QUOTATION

ITEM	QTY	DESCRIPTION	UNIT PRICE	SALE TOTAL
Contract Items:				
A	1	Godwin Dri-Prime CD140M Diesel Pump	\$ 49,891.40	\$ 49,891.40
		<ul style="list-style-type: none"> • 4" 150# Suction and Discharge • JCB TCAE-93 IT4 Diesel Engine • Includes PrimeGuard Engine Controller • Hwy Trailer, Elec Brakes, DOT Lights • Engine/Motor Options <ul style="list-style-type: none"> • Block Heater - 110 Volt • Battery Charger - 12 Volt Trickle • Base Options <ul style="list-style-type: none"> • Lights - 12 Volt Work Lights • (2) Moutned to headache bar 	<ul style="list-style-type: none"> 150.00 350.00 550.00 	<ul style="list-style-type: none"> 150.00 350.00 1,100.00
<p>*With purchase of above pump(s) we recommend that you also purchase the PM Service Kit(s) listed below:</p>				
	1	KTCD140MRS17 CD140M Diesel 1-2 yr Spares Kit	967.20	967.20
	1	KTJCBTCA93FK02 JCB TCAE-93 Engine Filter Kit	225.00	225.00
B	1	GL7 Drop in Trailer w/100 Gal Tank,	10,397.40	10,397.40
		<ul style="list-style-type: none"> • LED Lights, Hose Racks, Basket and • Diamond Plated Toolbox (10173) • Base Options <ul style="list-style-type: none"> • Hose Rack <ul style="list-style-type: none"> • (2) one mounted on each side to hold a total of (6) 6" x 10' suction hoses • Hose Basket <ul style="list-style-type: none"> • (1) to hold (3) 6" x 50' discharge hoses • Tool Box <ul style="list-style-type: none"> • Diamond Plated 	<ul style="list-style-type: none"> 0.00 0.00 0.00 	<ul style="list-style-type: none"> 0.00 0.00 0.00
Open Market Items:				
L	1	DELIVERY MOTOR FRT BR 037 PARTIAL LOAD	\$ 1,000.00	\$ 1,000.00
		<ul style="list-style-type: none"> • FOB - Shipping Point 		

Please note all sale pricing is in U.S. Dollars. The price does not include freight, export boxing, duties, taxes, or any other items not specifically mentioned.

SALE QUOTATION

ITEM	QTY	DESCRIPTION	UNIT PRICE	SALE TOTAL
M	1	4-1/4" Female QD x 150# Flange • Mounting Kit includes Adapter, • Flange Gasket, Bolts & Nuts • Mounted on Suction	124.53	124.53
N	1	4-1/4" Male QD x 150# Flange • Mounting Kit includes Adapter, • Flange Gasket, Bolts & Nuts • Mounted on Discharge	108.00	108.00
$ \begin{array}{r} \$ 64,313.53 \\ 334.49 \\ 1,278.32 \\ 130.58 \\ 97.16 \\ 95.92 \\ \hline -\$ 66,250.00 \\ \hline \end{array} $ + Shipping				
Net Sale Total with Recommended PM Service Kits				\$ 64,313.53
NET SALE TOTAL				\$ 63,121.33

Please note all sale pricing is in U.S. Dollars. The price does not include freight, export boxing, duties, taxes, or any other items not specifically mentioned.

option page

SALE QUOTATION

General Services Administration (GSA) pricing

ITEM	QTY	DESCRIPTION	UNIT PRICE	SALE TOTAL
Contract Items:				
<i>yes</i> A	1	Godwin PrimeGuard Float Set • w/ 65' Mechanical Floats	\$ 334.49	\$ 334.49
B	1	4" 90 Degree Godwin QD Bend	99.00	99.00
C	1	4" One Piece Suction Screen with Male Godwin QD Fittings	109.62	109.62
D	2	4" x 20' Light Weight Helix Hose with Godwin QD Fittings	232.94	465.88
<i>yes</i> E	2	4" X 20' Composite Hose with 150# Flange Fittings	639.16	1,278.32
F	2	4-1/4" Female QD x 150# Flange • Mounting Kit includes Adapter, • Flange Gasket, Bolts & Nuts	124.53	249.06
G	2	4-1/4" Male QD x 150# Flange • Mounting Kit includes Adapter, • Flange Gasket, Bolts & Nuts	108.00	216.00
<i>yes</i> H	1	6" Male Godwin QD x 4" Female Godwin QD Adapter	130.58	130.58
<i>yes</i> I	1	6" Female Cam & Groove x 6" Female NPT Adapter	97.16	97.16
<i>yes</i> J	1	6" Female Godwin QD x 6" Male NPT Adapter	95.92	95.92

NET SALE TOTAL

\$ 3,076.03

Please note all sale pricing is in U.S. Dollars. The price does not include freight, export boxing, duties, taxes, or any other items not specifically mentioned.